

**PART NUMBER:** 1633-DP

**TITLE:** 200W+3kW COMBINER BRIDGE DIPLEXER (DOUBLE CAVITY)

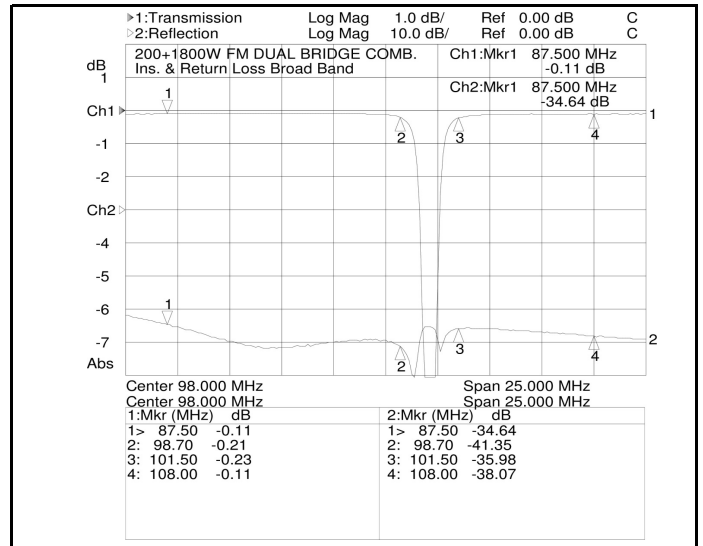
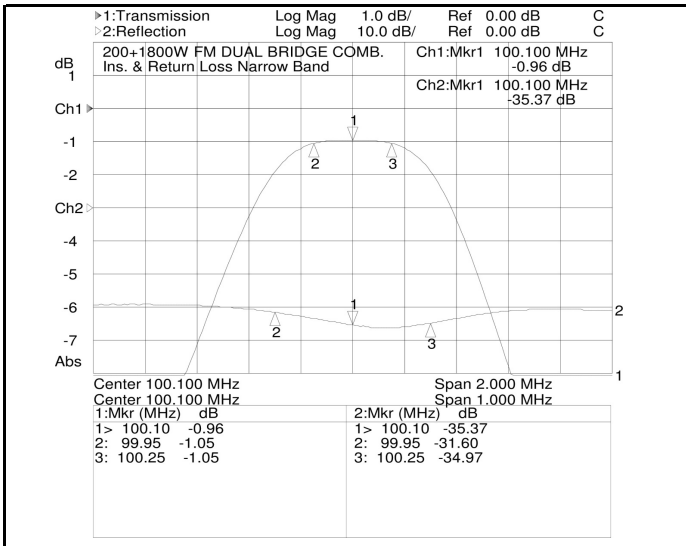
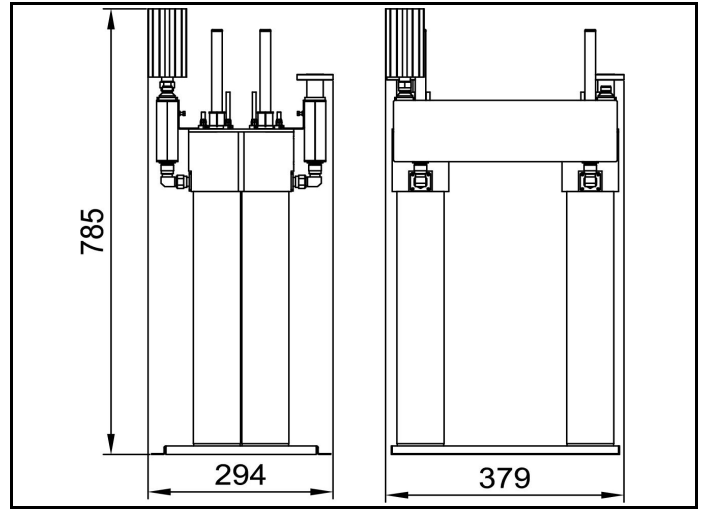
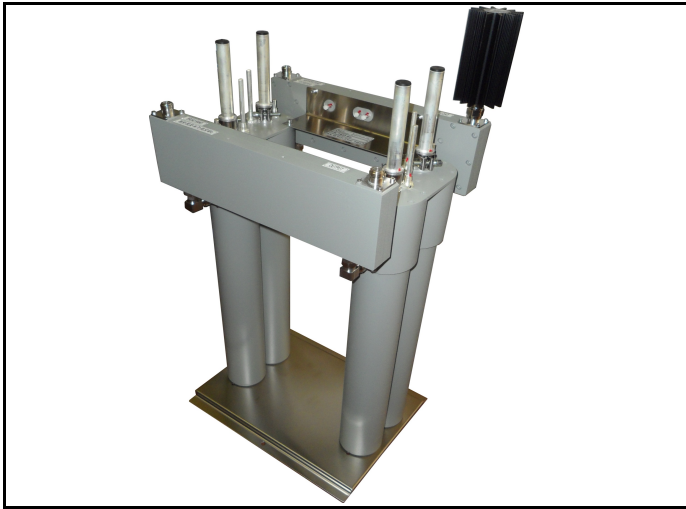

ELECTRICAL CHARACTERISTICS	
Frequency Range (MHz)	87.5 ÷ 108
N.B. Insertion Loss (dB)	< 1.05
B.B. Insertion Loss (dB)	< 0.2
Min. distance between channels (MHz)	1.4
Insulation NB>BB (dB)	> 40
Insulation BB>NB (dB)	> 40
Return loss by channels (dB)	> 26
Input/Output impedance (Ohm)	50
Narrowband maximum power (W)	200
Maximum output power (W)	3200

MECHANICAL CHARACTERISTICS	
Input narrowband	N
Input broadband	EIA 7/8"
Output	EIA 7/8"
Temperature range (C°)	-10 ÷ 50
Weight (kg)	22

(\*) Different connectors on request.